

# IC-PNEUMATIC

Diesel or LPG engine  
Pneumatic Tires

CMP15  
CMP18  
CMP20s

1500 kg  
1800 kg  
2000 kg

## CMP15/18/20s

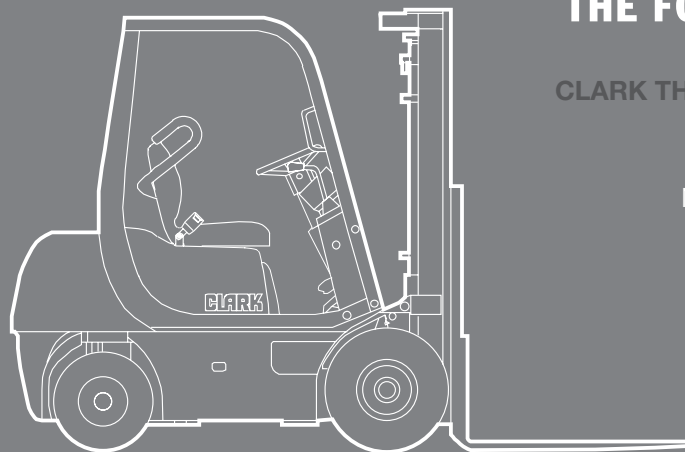

CLARK THE FORKLIFT

Europe

North America

South Korea

www.clarkmheu.com

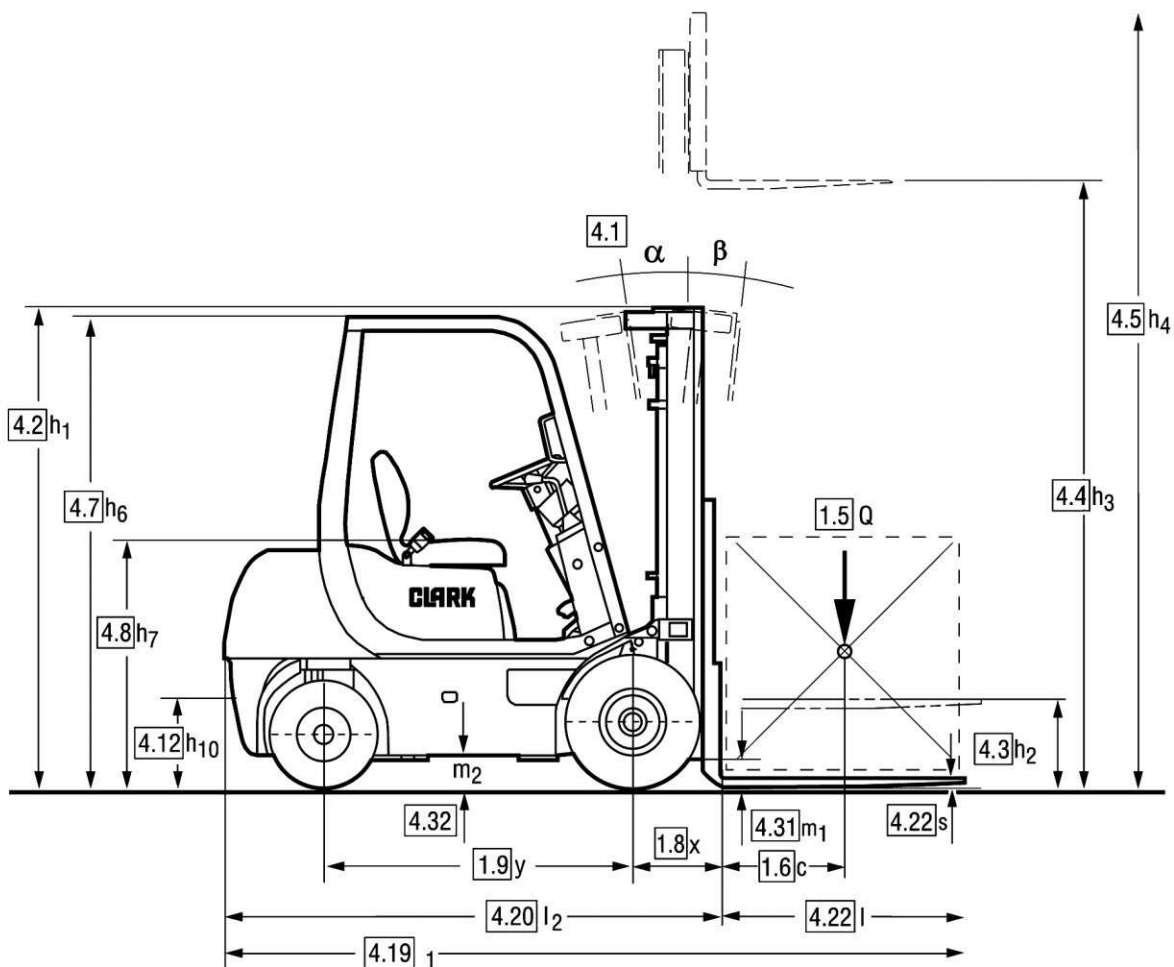

## CMP15/18/20s

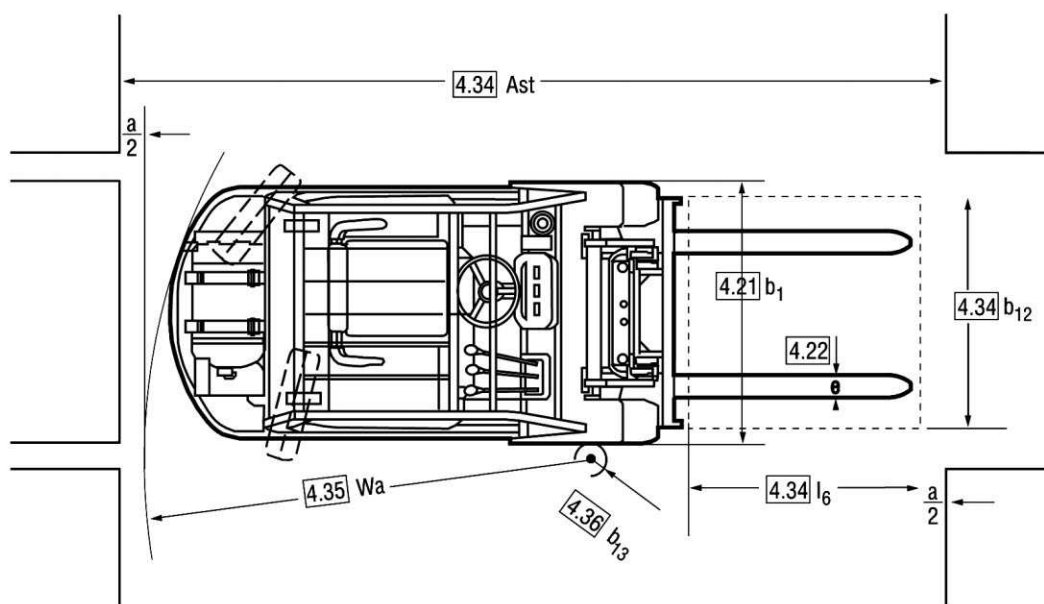

$$A_{st} = W_a + x + l_6 + a$$

$a = 200 \text{ mm (safety distance)}$

For corresponding data see  
Specification Chart.

## Truck Capacities

Capacity at different load centres

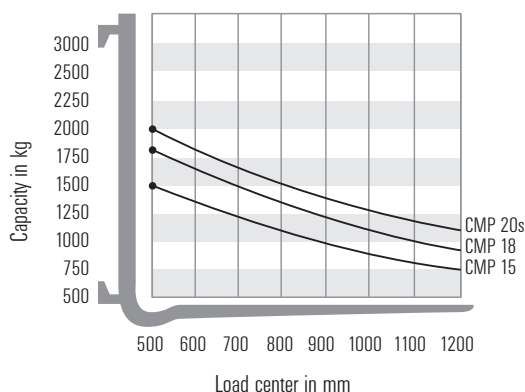

**Note:**

The listed capacities are valid only for the standard upright in vertical position with standard fork carriage and standard forks, up to max. lifting height of 3500 mm CMP 15-20s. The centre of gravity of the load may be displaced by max. 100 mm against the longitudinal centre line of the truck. Load centre is determined from top and front face of forks. The values are based on a 1000 mm cube load configuration with the centre of gravity at the true centre of the cube. With upright tilted forward lower capacity values are valid. Attachments, longer forks, exceptional load dimensions and higher lifting heights may reduce the capacity. Please contact your CLARK dealer if you require further information.

## Upright table

Capacity at different load centres

**Upright table metrics in mm**

CLARK Ref	max. fork height h3	overall height lowered h1	overall height raised h4*	free lift h2 h5*
-----------	---------------------	---------------------------	---------------------------	------------------

**Standard CMP 15, 18, 20s L/D**

(2 Stage Mast, standard free lift)

V	2000	1590	2590	100
V	2300	1740	2890	100
V	2500	1840	3009	100
V	2700	1940	3290	100
V	3000	2090	3590	100
V	3300	2240	3890	100
V	3500	2340	4009	100
V	3700	2440	4290	100
V	4000	2590	4590	100
V	4500	3055	5009	100
V	5000	3305	5590	100

\* without LBR

**Upright table metrics in mm**

CLARK Ref	max. fork height h3	overall height lowered h1	overall height raised h4*	free lift h2 h5*
-----------	---------------------	---------------------------	---------------------------	------------------

**Triple CMP 15, 18, 20s L/D**

(3 Stage Mast, full free lift)

M	3700	1855	4295	1310
M	4000	1955	4595	1410
M	4300	2055	4895	1510
M	4500	2120	5095	1580
M	4800	2220	5395	1680
M	5000	2290	5595	1745
M	5500	2495	6095	1960
M	6000	2740	6595	2205
M	6500	2910	7095	2237
M	7000	3155	7595	2618

\* without LBR

## LPG engine

according to VDI 2198

All values shown are for standard lift truck with standard equipment. If the truck is supplied with options, values may change. All values given may vary +5% and -10% due to the motor and system tolerances and represent nominal values obtained under typical operating conditions. Specifications for Non-emission limited truck.

# SPECIFICATIONS

1.1 Manufacture (Abbreviation)		CLARK	CLARK	CLARK		
Characteristics	1.2 Manufacture's designation	<b>CMP 15 L</b>	<b>CMP 18 L</b>	<b>CMP 20s L</b>		
	1.3 Drive Unit Diesel, L.P. Gas	LPG	LPG	LPG		
	1.4 Operator type stand on / driver seated	driver seated	driver seated	driver seated		
	1.5 Load Capacity / rated load	Q (t)	1,5	1,8	2,0	
	1.6 Load Center distance	c (mm)	500	500	500	
	1.8 Load Center distance, centre of drive axle to fork face	x (mm)	390	390	390	
	1.9 Wheelbase	y (mm)	1350	1350	1350	
	Weight	2.1 Service weight	kg	2780 (2690)	2900 (2820)	3110 (3070)
		2.2 Axle loading, laden front / rear	kg	3740/540 (3730/460)	4210/490 (4070/550)	4480/630 (4390/680)
2.3 Axle loading, unladen front / rear		kg	1270/1510 (1240/1450)	1230/1670 (1090/1730)	1180/1930 (1070/2000)	
Tires, Chassis	3.1 Tire type, P=pneumatic, SE=superelastic, C=cushion 1)		P	P	P	
	3.2 Tire size, front		6.50 x 10-12PR	6.50 x 10-12PR	6.50 x 10-12PR	
	3.3 Tire size, rear		5 x8-8PR	5x8-8PR	5x8-8PR	
	3.5 Wheels, number front / rear (x=drive wheels)		2x/2	2x/2	2x/2	
	3.6 Tread, front	b <sub>10</sub> (mm)	930	930	930	
	3.7 Tread, rear	b <sub>11</sub> (mm)	900	900	900	
	Dimensions	4.1 Tilt of upright / fork carriage, α/β	deg	10/6	10/6	10/6
4.2 Height, upright lowered		h <sub>1</sub> (mm)	2097	2097	2097	
4.3 Freelift		h <sub>2</sub> (mm)	110	110	110	
4.4 Lift height 2)		h <sub>3</sub> (mm)	3000	3000	3000	
4.5 Height upright extended 6)		h <sub>4</sub> (mm)	3656	3656	3656	
4.7 Height overheadguard (cab): Std / Container		h <sub>6</sub> (mm)	2060	2060	2060	
4.8 Seat height		h <sub>7</sub> (mm)	1025	1025	1075	
4.12 Coupling height		h <sub>10</sub> (mm)	-	-	-	
4.19 Overall length		l <sub>1</sub> (mm)	3240	3265	3310	
4.20 Length to face of forks		l <sub>2</sub> (mm)	2170	2195	2240	
4.21 Width		b <sub>1</sub> /b <sub>2</sub> (mm)	1110	1110	1110	
4.22 Fork dimensions		s/e/l (mm)	40 x 100 x 1070	40 x 100 x 1070	40 x 100 x 1070	
4.23 Fork carriage DIN 15173, A, B			II A	II A	II A	
4.24 Fork carriage width		b <sub>3</sub> (mm)	940	940	940	
4.31 Ground clearance minimum, unladen		m <sub>1</sub> (mm)	114	114	114	
4.32 Ground clearance center of wheelbase		m <sub>2</sub> (mm)	117	117	117	
4.34 Stacking aisle for pallets 800x1200 (l <sub>6</sub> -b <sub>12</sub> )			-	-	-	
4.34 Stacking aisle for pallets 1000x1200 (l <sub>6</sub> -b <sub>12</sub> )		A <sub>st</sub> (mm)	3625	3645	3690	
4.34 Stacking aisle for pallets 1200x800 (l <sub>6</sub> -b <sub>12</sub> )	A <sub>st</sub> (mm)	-	-	-		
4.35 Turning radius	W <sub>a</sub> (mm)	2035	2055	2100		
4.36 Internal turning radius	b <sub>13</sub> (mm)	-	-	-		
Performance	5.1 Travel speed laden/unladen	km/h	17,1/17,8	17,0/17,8	16,9/17,9	
	5.2 Lift speed laden/unladen	m/s	0,53/0,57	0,51/0,57	0,50/0,57	
	5.3 Lowering speed laden/unladen	m/s	0,51/0,51	0,51/0,51	0,51/0,50	
	5.6 Max. drawbar pull laden/unladen 4)	N	14749/9610 (13240/5880)	14837/9512 (13240/5110)	14896/9414 (12750/5790)	
	5.8 Max. gradeability laden 3)/unladen 4)	%	37,0/20,8 (31,8/20,0)	33,6/19,5 (28,5/16,8)	31,1/17,4 (26,0/16,0)	
	5.9 Acceleration time laden/unladen (0 - 15 m)	s	-/-	-/-	-/-	
	5.10 Service brake 6)		hydraulic	hydraulic	hydraulic	
Drive Line	7.1 Manufacturer / Type		Mitsubishi 4G63	Mitsubishi 4G63	Mitsubishi 4G63	
	7.2 Rated output acc. DIN 70 020	kW	25	25	25	
	7.3 Rated speed acc. DIN 70 020	min <sup>-1</sup>	2300	2300	2300	
	7.4 No. of cylinders / displacement	/cm <sup>3</sup>	4/2000	4/2000	4/2000	
	7.5 Fuel consumption acc. VDI-Cycles	Diesel=l/h, L.P.Gas=kg/h	-	-	-	
Miscellaneous	8.1 Type of control		hydrodyn.	hydrodyn.	hydrodyn.	
	8.2 Operating pressure for attachments	bar	170	170	170	
	8.3 Oil volume for attachments	l/min	-	-	-	
	8.4 Sound level, driver's ear 5)	dB (A)	83	83	83	
	8.5 Towing coupling, class/type DIN		-	-	-	

1) Optional with super-elastic tires 2) Further lift heights see upright table 3) Laden with 1,6 km/h 4) Without load at friction coefficient  $\mu = 0,8$

5) Equivalent permanent sound-pressure level L<sub>pAeq,T</sub> in accordance with DIN EN 12053 6) Without load backrest

## Diesel engine

according to VDI 2198

All values shown are for standard lift truck with standard equipment. If the truck is supplied with options, values may change. All values given may vary +5% and -10% due to the motor and system tolerances and represent nominal values obtained under typical operating conditions. Specifications for Non-emission limited truck.

# SPECIFICATIONS

1.1 Manufacture (Abbreviation)		CLARK	CLARK	CLARK	
Characteristics	1.2 Manufacture's designation	<b>CMP 15 D</b>	<b>CMP 18 D</b>	<b>CMP 20S D</b>	
	1.3 Drive Unit Diesel, L.P. Gas	Diesel	Diesel	Diesel	
	1.4 Operator type stand on / driver seated	driver seated	driver seated	driver seated	
	1.5 Load Capacity / rated load	Q (t)	1,5	1,8	2,0
	1.6 Load Center distance	c (mm)	500	500	500
	1.8 Load Center distance, centre of drive axle to fork face	x (mm)	390	390	390
	1.9 Wheelbase	y (mm)	1350	1350	1350
Weight	2.1 Service weight	kg	2810 (2690)	2930 (2820)	3140 (3070)
	2.2 Axle loading, laden front / rear	kg	3770/540 (3730/460)	4230/500 (4070/550)	4510/630 (4390/680)
	2.3 Axle loading, unladen front / rear	kg	1290/1520 (1240/1450)	1260/1670 (1090/1730)	1200/1940 (1070/2000)
Tires, Chassis	3.1 Tire type, P=pneumatic, SE=superelastic, C=cushion 1)		P	P	P
	3.2 Tire size, front		6.50 x 10-12PR	6.50 x 10-12PR	6.50 x 10-12PR
	3.3 Tire size, rear		5 x8-10PR	5x8-10PR	5x8-10PR
	3.5 Wheels, number front / rear (x=drive wheels)		2x/2	2x/2	2x/2
	3.6 Tread, front	b <sub>10</sub> (mm)	930	930	930
	3.7 Tread, rear	b <sub>11</sub> (mm)	900	900	900
	Dimensions	4.1 Tilt of upright / fork carriage, α/β	deg	10/6	10/6
4.2 Height, upright lowered		h <sub>1</sub> (mm)	2097	2097	2097
4.3 Freelift		h <sub>2</sub> (mm)	110	110	110
4.4 Lift height 2)		h <sub>3</sub> (mm)	3000	3000	3000
4.5 Height upright extended 6)		h <sub>4</sub> (mm)	3656	3656	3656
4.7 Height overheadguard (cab): Std / Container		h <sub>6</sub> (mm)	2060	2060	2060
4.8 Seat height		h <sub>7</sub> (mm)	1025	1025	1075
4.12 Coupling height		h <sub>10</sub> (mm)	-	-	-
4.19 Overall length		l <sub>1</sub> (mm)	3240	3265	3310
4.20 Length to face of forks		l <sub>2</sub> (mm)	2170	2195	2240
4.21 Width		b <sub>1</sub> /b <sub>2</sub> (mm)	1110	1110	1110
4.22 Fork dimensions		s/e/l (mm)	40 x 100 x 1070	40 x 100 x 1070	40 x 100 x 1070
4.23 Fork carriage DIN 15173, A, B			II A	II A	II A
4.24 Fork carriage width		b <sub>3</sub> (mm)	940	940	940
4.31 Ground clearance minimum, unladen		m <sub>1</sub> (mm)	114	114	114
4.32 Ground clearance center of wheelbase		m <sub>2</sub> (mm)	117	117	117
4.34 Stacking aisle for pallets 800x1200 (l <sub>6</sub> -b <sub>12</sub> )			-	-	-
4.34 Stacking aisle for pallets 1000x1200 (l <sub>6</sub> -b <sub>12</sub> )	A <sub>st</sub> (mm)	3625	3645	3690	
4.34 Stacking aisle for pallets 1200x800 (l <sub>6</sub> -b <sub>12</sub> )	A <sub>st</sub> (mm)	-	-	-	
4.35 Turning radius	W <sub>a</sub> (mm)	2035	2055	2100	
4.36 Internal turning radius	b <sub>13</sub> (mm)	-	-	-	
Performance	5.1 Travel speed laden/unladen	km/h	17,2/17,9	17,2/17,9	17,1/18,0
	5.2 Lift speed laden/unladen	m/s	0,53/0,57	0,51/0,57	0,50/0,57
	5.3 Lowering speed laden/unladen	m/s	0,51/0,51	0,51/0,51	0,51/0,50
	5.6 Max. drawbar pull laden/unladen 4)	N	15779/9610 (16670/8340)	15887/9512 (16670/8340)	15946/9414 (16670/8340)
	5.8 Max. gradeability laden 3)/unladen 4)	%	39,7/21,0 (39/21)	36,0/19,7 (36/18)	33,3/17,6 (33/15)
	5.9 Acceleration time laden/unladen (0 - 15 m)	s	-/-	-/-	-/-
	5.10 Service brake 6)		hydraulic	hydraulic	hydraulic
Drive Line	7.1 Manufacturer / Type		Yanmar 4TNV88	Yanmar 4TNV88	Yanmar 4TNV88
	7.2 Rated output acc. DIN 70 020	kW	28,8	28,8	28,8
	7.3 Rated speed acc. DIN 70 020	min <sup>-1</sup>	2400	2400	2400
	7.4 No. of cylinders / displacement	/cm <sup>3</sup>	4/2190	4/2190	4/2190
	7.5 Fuel consumption acc. VDI-Cycles	Diesel=l/h, L.P.Gas=kg/h	-	-	-
Miscellaneous	8.1 Type of control		hydrodyn.	hydrodyn.	hydrodyn.
	8.2 Operating pressure for attachments	bar	170	170	170
	8.3 Oil volume for attachments	l/min	-	-	-
	8.4 Sound level, driver's ear 5)	dB (A)	81	81	81
	8.5 Towing coupling, class/type DIN		-	-	-

1) Optional with super-elastic tires 2) Further lift heights see upright table 3) Laden with 1,6 km/h 4) Without load at friction coefficient  $\mu = 0,8$

5) Equivalent permanent sound-pressure level L<sub>pAeq,T</sub> in accordance with DIN EN 12053 6) Without load backrest

**Operator cell**

It is easy for the driver to access the operator's seat. Great freedom of movement and all ergonomics are designed for customer's comfort and convenience. Large floorboard area accommodates large boots.

**Motor**

The motors of the CMP 15-20s series are powerful and durable. The implemented Mitsubishi model 4G63 LPG engine with internal dynamic balancers reduces vibrations. Camshaft and balancers are cog belt driven. Cast iron deep skirt block with aluminium cylinder head, 5-main bearing crankshaft, hydraulic valve lifters and electronic ignition reduce maintenance requirements. An automatic engine shut-down system protects the engine from high engine coolant temperature or low engine oil pressure. This engine is well known for low maintenance and long service life.

An optional Yanmar model 4TNV88, Diesel engine with direct injection is also available. Vertical exhaust is standard on Diesel. 2004 EPA compliant, not U.L. listed.

**Brakes**

Self-energizing, hydraulic-actuated drum and shoe type service brakes. Heavy cast iron brake shoes, backing plates and drums with openings for lining inspection and adjustment. All components are asbestos-free. The brakes are accessed by removing the wheel hub, axleshaft and brake drum. The left hand actuated parking brake pedal actuates service brakes at both drive wheels, with electric transmission interrupt and fingertip release. The transmission is disengaged when the parking brake is applied.

**Steering**

Steering is full hydrostatic with tilt wheel, utilizing a compact axle beam and integral double-acting steer cylinder. High strength spindle assemblies incorporate kingpins and double metal sealed bearings to provide rugged, easily serviced assemblies. The steering linkage uses spherical bearings, double shear link pins and grease fittings. Rubber isolation mounts support the axle, absorb shock and reduce noise.

**Hydraulics**

A single gear driven pump provides fluid for hydraulic functions and steering. The priority-demand steering system conserves energy by supplying hydraulic fluid on demand only basis. The hydraulic tank is integral with the truck frame with an in-tank screen, and the in-tank return line filter is easily serviced without spill. A quick-connect pressure port allows convenient pressure checks.

**Upright Assembly**

High visibility CLARK designed uprights are available in two stage, HiLo and triple stage full free lift designs and are configured to provide maximum forward visibility. A wide range of lift heights is available. Interlocking rail/nested roller upright design utilizes specially rolled inner rail and channel section outer rails. This provides high strength under all upright load conditions and greater tolerance to unbalanced loads. Uprights feature negative rail drop enabling upright rollers to be easily accessed for adjustment.

Tilt cylinders incorporate spherical bushings at both ends to extend seal life by minimizing axial cylinder loads. Hydraulic counterbalance valve prevents improper tilt cylinder operation, flow limiting valves protect against rapid carriage descent in the event of a line failure and a lowering control valve regulates lowering speeds. ITA Class II and III hook type carriages incorporate six main rollers and two side thrust rollers to resist deflection due to off center loads. Forks are upset forged and have adjustable fork locks; forks are retained by the load backrest extension.

**Miscellaneous standard**

A single auxiliary valve, internal hosing, sidseshifter, two headlights mounted on the overhead guard, tail lights, brake lights, turn signals and flashers are all standard equipment. Other standard features are open core radiator, high air intake, tow pin in the counterweight, rear tie-downs, low fuel warning indicator. The operator manual is permanently attached inside the rear pocket of the comfortable safety seat. Color is high visibility CLARK Green with matte black operator cell and upright. Wheels are bright white. CLARK's Employer's Guide to Material Handling Safety and operator safety video are provided with truck.



**CLARK Europe GmbH**

Neckarstraße 37  
 D - 45478 Mülheim an der Ruhr  
 Tel. +49 208 377336 0  
 Fax +49 208 377336 36  
 email: info-europe@clarkmheu.com  
 www.clarkmheu.com

**Your authorized CLARK dealer is:**