

IC-PNEUMATIC

Diesel or LPG engine
Pneumatic Tires

CMP20
CMP25
CMP30

2000 kg
2500 kg
3000 kg

CMP20/25/30

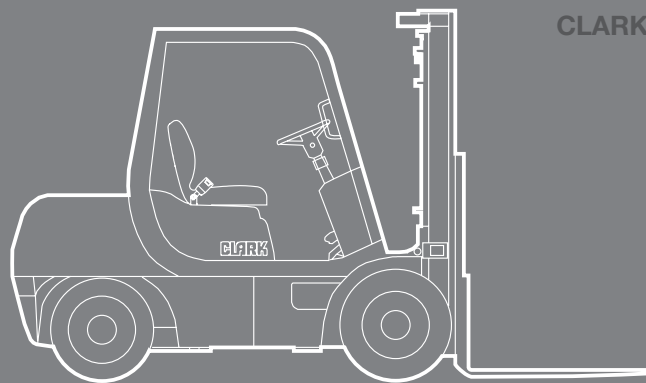

CLARK THE FORKLIFT

Europe

North America

South Korea

w w w . c l a r k m h e u . c o m

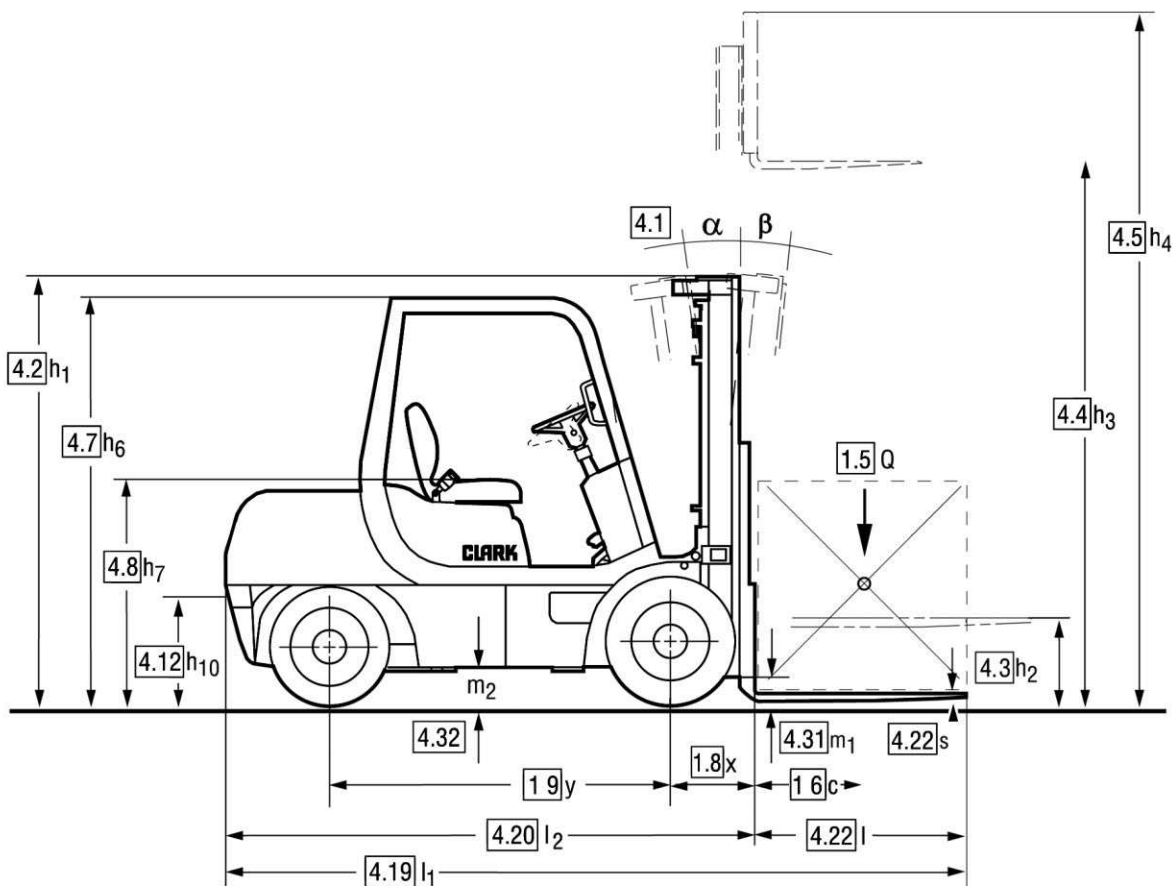

CMP20/25/30

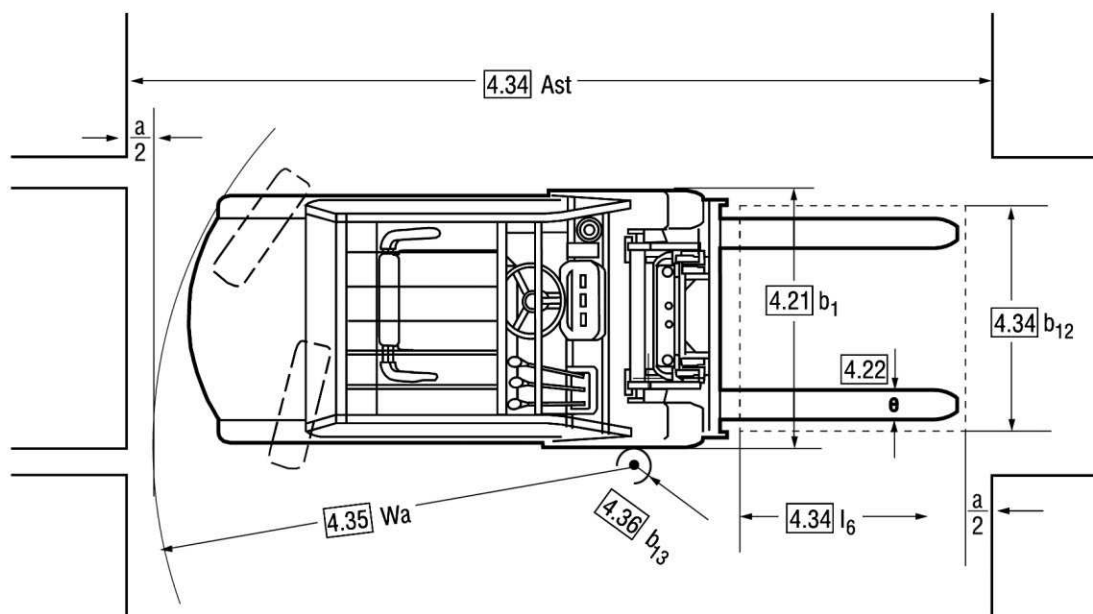

$$A_{st} = W_a + x + l_6 + a$$

$$a = 200 \text{ mm (safety distance)}$$

For corresponding data see
Specification Chart.

Truck Capacities

Capacity at different load centres

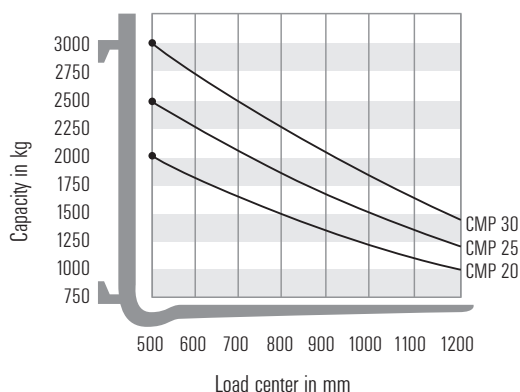

Note:

The listed capacities are valid only for the standard upright in vertical position with standard fork carriage and standard forks, up to max. lifting height of 3300 mm CMP 20-30. The centre of gravity of the load may be displaced by max. 100 mm against the longitudinal centre line of the truck. Load centre is determined from top and front face of forks. The values are based on a 1000 mm cube load configuration with the centre of gravity at the true centre of the cube. With upright tilted forward lower capacity values are valid. Attachments, longer forks, exceptional load dimensions and higher lifting heights may reduce the capacity. Please contact your CLARK dealer if you require further information.

Upright table

Capacity at different load centres

Upright table metrics in mm

CLARK Ref	max. fork height h3	overall height lowered h1	overall height raised h4*	free lift h2 h5*
-----------	---------------------	---------------------------	---------------------------	------------------

Standard CMP 20, 25, 30 L/D

(2 Stage Mast, standard free lift)

V	2000	1595	2670	105
V	2300	1745	2970	105
V	2500	1845	3170	105
V	2700	1945	3370	105
V	3000	2095	3670	105
V	3300	2245	3970	105
V	3500	2345	4170	105
V	3700	2445	4370	105
V	4000	2595	4670	105
V	4500	3055	6170	105
V	5000	3305	5670	105

* without LBR

Upright table metrics in mm

CLARK Ref	max. fork height h3	overall height lowered h1	overall height raised h4*	free lift h2 h5*
-----------	---------------------	---------------------------	---------------------------	------------------

Hi-Lo CMP 20, 25, 30 L/D

(2 Stage Mast, full free lift)

H	2700	1980	-	1400
H	3000	2130	-	1550
H	3300	2280	-	1700

* without LBR

Upright table metrics in mm

CLARK Ref	max. fork height h3	overall height lowered h1	overall height raised h4*	free lift h2 h5*
-----------	---------------------	---------------------------	---------------------------	------------------

Triple CMP 20, 25, 30 L/D

(3 Stage Mast, full free lift)

M	3700	1870	4375	1240
M	4000	1970	4675	1340
M	4300	2070	4975	1440
M	4500	2135	5175	1505
M	4700	2200	5375	1650
M	4800	2250	5475	1650
M	5000	2300	5675	1670
M	5500	2510	6175	1880
M	6000	2750	6675	2120
M	6500	2925	7175	2300
M	7000	3165	7675	2540

* without LBR

LPG engine

according to VDI 2198

All values shown are for standard lift truck with standard equipment. If the truck is supplied with options, values may change. All values given may vary +5% and -10% due to the motor and system tolerances and represent nominal values obtained under typical operating conditions. Specifications for Non-emission limited truck.

SPECIFICATIONS

1.1 Manufacture (Abbreviation)		CLARK	CLARK	CLARK		
Characteristics	1.2 Manufacture's designation	CMP 20 L	CMP 25 L	CMP 30 L		
	1.3 Drive Unit Diesel, L.P. Gas	L.P.-Gas	L.P.-Gas	L.P.-Gas		
	1.4 Operator type stand on / driver seated	driver seated	driver seated	driver seated		
	1.5 Load Capacity / rated load	Q (t)	2,0	2,5	3,0	
	1.6 Load Center distance	c (mm)	500	500	500	
	1.8 Load Center distance, centre of drive axle to fork face	x (mm)	450	450	450	
	1.9 Wheelbase	y (mm)	1620	1620	1700	
	Weight	2.1 Service weight	kg	3490	3720	4160
		2.2 Axle loading, laden front / rear	kg	4730/760	5520/700	6280/880
2.3 Axle loading, unladen front / rear		kg	1630/1860	1580/2140	1610/2550	
Tires, Chassis	3.1 Tire type, P=pneumatic, SE=superelastic, C=cushion 1)	P	P	P		
	3.2 Tire size, front	7.00 x 12-14PR	7.00 x 12-14PR	8.15 x 15-14PR		
	3.3 Tire size, rear	6.50 x 10-10PR	6.50 x 10-10PR	6.50 x 10-10PR		
	3.5 Wheels, number front / rear (x=drive wheels)	2x/2	2x/2	2x/2		
	3.6 Tread, front	b ₁₀ (mm)	1005	1005	1030	
	3.7 Tread, rear	b ₁₁ (mm)	940	940	940	
	Dimensions	4.1 Tilt of upright / fork carriage, α/β	deg	10/8	10/8	10/8
4.2 Height, upright lowered		h ₁ (mm)	2245	2245	2245	
4.3 Freelift		h ₂ (mm)	105	105	105	
4.4 Lift height 2)		h ₃ (mm)	3300	3300	3300	
4.5 Height upright extended 6)		h ₄ (mm)	3970	3970	3970	
4.7 Height overheadguard (cab): Std / Container		h ₆ (mm)	2130	2130	2130	
4.8 Seat height		h ₇ (mm)	1090	1090	1090	
4.12 Coupling height		h ₁₀ (mm)	-	-	-	
4.19 Overall length		l ₁ (mm)	3615	3650	3755	
4.20 Length to face of forks		l ₂ (mm)	2545	2580	2685	
4.21 Width		b ₁ /b ₂ (mm)	1210	1210	1240	
4.22 Fork dimensions		s/e/l (mm)	45 x 100 x 1070	45 x 100 x 1070	45 x 125 x 1070	
4.23 Fork carriage DIN 15173, A, B			II A	II A	III A	
4.24 Fork carriage width		b ₃ (mm)	1041	1041	1041	
4.31 Ground clearance minimum, unladen		m ₁ (mm)	120	120	120	
4.32 Ground clearance center of wheelbase		m ₂ (mm)	175	175	175	
4.34 Stacking aisle for pallets 800x1200 (l ₆ -b ₁₂)			3800	3840	3950	
4.34 Stacking aisle for pallets 1000x1200 (l ₆ -b ₁₂)		A _{st} (mm)	4000	4040	4150	
4.34 Stacking aisle for pallets 1200x800 (l ₆ -b ₁₂)	A _{st} (mm)	4200	4240	4350		
4.35 Turning radius	W _a (mm)	2350	2390	2500		
4.36 Internal turning radius	b ₁₃ (mm)	-	-	-		
Performance	5.1 Travel speed laden/unladen	km/h	17,6/18,6	17,6/18,6	18,0/19,0	
	5.2 Lift speed laden/unladen	m/s	0,52/0,56	0,50/0,56	0,48/0,56	
	5.3 Lowering speed laden/unladen	m/s	0,51/0,51	0,51/0,51	0,51/0,51	
	5.6 Max. drawbar pull laden/unladen 4)	N	16062/9731 (13340/7850)	16150/9437 (13390/7550)	16170/9613 (12650/7650)	
	5.8 Max. gradeability laden 3) /unladen 4)	%	31,1/22,2 (23,1/21,9)	27,4/20,3 (21,8/20,0)	23,6/18,8 (18,3/18,6)	
	5.9 Acceleration time laden/unladen (0 - 15 m)	s	-/-	-/-	-/-	
	5.10 Service brake		hydraulic	hydraulic	hydraulic	
Drive Line	7.1 Manufacturer / Type		Mitsubishi 4G64	Mitsubishi 4G64	Mitsubishi 4G64	
	7.2 Rated output acc. ISO 1585	kW	30	30	30	
	7.3 Rated speed	min ⁻¹	2100	2100	2100	
	7.4 No. of cylinders / displacement	/cm ³	4/2350	4/2350	4/2350	
	7.5 Fuel consumption acc. VDI-Cycles		-	-	-	
Miscellaneous	8.1 Type of control		-	-	-	
	8.2 Operating pressure for attachments	bar	140	140	140	
	8.3 Oil volume for attachments	l/min	-	-	-	
	8.4 Sound level, driver's ear 5)	dB (A)	-	-	-	
	8.5 Towing coupling, class/type DIN		pin	pin	pin	

1) Optional solid tires 2) For further lift heights, see upright table 3) Laden at 1.6 kph 4) Unladen at $\mu = 0.8$

5) Equivalent permanent sound-pressure level L_{pAeq,T} in accordance with DIN EN 12053 6) Without LBR

Diesel engine

according to VDI 2198

All values shown are for standard lift truck with standard equipment. If the truck is supplied with options, values may change. All values given may vary +5% and -10% due to the motor and system tolerances and represent nominal values obtained under typical operating conditions. Specifications for Non-emission limited truck.

SPECIFICATIONS

1.1 Manufacture (Abbreviation)		CLARK	CLARK	CLARK		
Characteristics	1.2 Manufacture's designation	CMP 20 D	CMP 25 D	CMP 30 D		
	1.3 Drive Unit Diesel, L.P. Gas	Diesel	Diesel	Diesel		
	1.4 Operator type stand on / driver seated	driver seated	driver seated	driver seated		
	1.5 Load Capacity / rated load	Q (t)	2,0	2,5	3,0	
	1.6 Load Center distance	c (mm)	500	500	500	
	1.8 Load Center distance, centre of drive axle to fork face	x (mm)	450	450	450	
	1.9 Wheelbase	y (mm)	1620	1620	1700	
	Weight	2.1 Service weight	kg	3560	3780	4200
		2.2 Axle loading, laden front / rear	kg	4850/710	5580/700	6360/840
2.3 Axle loading, unladen front / rear		kg	1680/1880	1610/2170	1680/2520	
Tires, Chassis	3.1 Tire type, P=pneumatic, SE=superelastic, C=cushion 1)	P	P	P		
	3.2 Tire size, front	7.00 x 12-14PR	7.00 x 12-14PR	8.15 x 15-14PR		
	3.3 Tire size, rear	6.50 x 10-10PR	6.50 x 10-10PR	6.50 x 10-10PR		
	3.5 Wheels, number front / rear (x=drive wheels)	2x/2	2x/2	2x/2		
	3.6 Tread, front	b ₁₀ (mm)	1005	1005	1030	
	3.7 Tread, rear	b ₁₁ (mm)	940	940	940	
	Dimensions	4.1 Tilt of upright / fork carriage, α/β	deg	10/8	10/8	10/8
4.2 Height, upright lowered		h ₁ (mm)	2245	2245	2245	
4.3 Freelift		h ₂ (mm)	105	105	105	
4.4 Lift height 2)		h ₃ (mm)	3300	3300	3300	
4.5 Height upright extended 6)		h ₄ (mm)	3970	3970	3970	
4.7 Height overheadguard (cab): Std / Container		h ₆ (mm)	2130	2130	2130	
4.8 Seat height		h ₇ (mm)	1090	1090	1090	
4.12 Coupling height		h ₁₀ (mm)	-	-	-	
4.19 Overall length		l ₁ (mm)	3615	3650	3755	
4.20 Length to face of forks		l ₂ (mm)	2545	2580	2685	
4.21 Width		b ₁ /b ₂ (mm)	1210	1210	1240	
4.22 Fork dimensions		s/e/l (mm)	45 x 100 x 1070	45 x 100 x 1070	45 x 125 x 1070	
4.23 Fork carriage DIN 15173, A, B			II A	II A	III A	
4.24 Fork carriage width		b ₃ (mm)	1041	1041	1041	
4.31 Ground clearance minimum, unladen		m ₁ (mm)	120	120	120	
4.32 Ground clearance center of wheelbase		m ₂ (mm)	175	175	175	
4.34 Stacking aisle for pallets 800x1200 (l ₆ -b ₁₂)			3800	3840	3950	
4.34 Stacking aisle for pallets 1000x1200 (l ₆ -b ₁₂)		A _{st} (mm)	4000	4040	4150	
4.34 Stacking aisle for pallets 1200x800 (l ₆ -b ₁₂)	A _{st} (mm)	4200	4240	4350		
4.35 Turning radius	W _a (mm)	2350	2390	2500		
4.36 Internal turning radius	b ₁₃ (mm)	-	-	-		
Performance	5.1 Travel speed laden/unladen	km/h	19,2/20,4	18,9/20,4	19,6/20,8	
	5.2 Lift speed laden/unladen	m/s	0,55/0,59	0,53/0,59	0,51/0,59	
	5.3 Lowering speed laden/unladen	m/s	0,51/0,51	0,51/0,51	0,51/0,51	
	5.6 Max. drawbar pull laden/unladen 4)	N	18669/10000 (16080/8040)	16807/9607 (16130/7650)	16571/10025 (15200/8040)	
	5.8 Max. gradeability laden 3)/unladen 4)	%	31,1/22,2 (30,6/22,2)	28,1/20,2 (26,9/20,2)	24,0/19,3 (21,9/19,3)	
	5.9 Acceleration time laden/unladen (0 - 15 m)	s	-/-	-/-	-/-	
	5.10 Service brake		hydraulic	hydraulic	hydraulic	
Drive Line	7.1 Manufacturer / Type		Yanmar 4TNV94	Yanmar 4TNV94	Yanmar 4TNV94	
	7.2 Rated output acc. ISO 1585	kW	42,8	42,8	42,8	
	7.3 Rated speed	min ⁻¹	2500	2500	2500	
	7.4 No. of cylinders / displacement	/cm ³	4/2776	4/2776	4/2776	
	7.5 Fuel consumption acc. VDI-Cycles	Diesel=l/h, L.P.Gas=kg/h	-	-	-	
Miscellaneous	8.1 Type of control		hydrodyn.	hydrodyn.	hydrodyn.	
	8.2 Operating pressure for attachments	bar	140	140	140	
	8.3 Oil volume for attachments	l/min	-	-	-	
	8.4 Sound level, driver's ear 5)	dB (A)	-	-	-	
	8.5 Towing coupling, class/type DIN		pin	pin	pin	

1) Optional solid tires 2) For further lift heights, see upright table 3) Laden at 1.6 kph 4) Unladen at μ = 0.8

5) Equivalent permanent sound-pressure level L_{pAeq,T} in accordance with DIN EN 12053 6) Without LBR

CLARK CMP 20 SERIES pneumatic tire trucks are designed for durability and ease of operation. They are ideal for both indoor and outdoor applications in manufacturing, warehousing and distribution operations. Equipped with single-speed powershift transaxles and LPG, dual fuel or diesel engines to suit the most rugged demands.

Operator Control & Comfort

The CMP20 Series provides high levels of operator comfort and control while meeting expectations productivity and durability.

An isolated operator cell supported on rubber mounts reduces vibration and sound transmission to the operator seat and controls. Low in-frame steps on both sides, 17.1 in. (435 mm) high, enable easy access to the operator compartment. A rubber floor mat makes footing secure. Cowl-mounted hydraulic control levers provide short reach and low effort enabling precise load control. Electric directional control lever allows “fingertip” operation of the powershift transaxle. The tilt steering wheel can be secured at any position within its range of travel. A two-pedal inchbrake system provides excellent control and comfort; left pedal is for inch and brake operation, right pedal for brakes only.

Equipped with a legendary CLARK safety seat with shoulder restraints, adjustable and fold-down back rest, molded bolsters for comfort and support, six inches (150 mm) fore/aft adjustment, a retractable seat belt and an operator manual in the seat pocket. Rear-hinged clamshell hood with locking gas cylinder strut makes access for daily inspection convenient.

The high visibility upright, overhead guard and load backrest designs improve operator vision during travel and stacking operations.

Instrument Panel

An operator display monitor includes indicator lights for engine oil pressure, check engine light, battery charge, transmission temperature, park brake “on”, low LPG, Glow plugs (diesel) turn signal indicators and panel test light. Five digit hour meter, analog engine temperature gauge and fuel gauge (dual fuel and diesel models) are provided on the display.

Engine

Featuring a Mitsubishi model 4G64, 2.4 liter (143 c.i.) 4-cylinder overhead cam engine with internal dynamic balancers for reduced vibration and an EPA 2004 compliant LPG fuel system with diagnostics. Camshaft and balancers are cog belt driven. Cast iron deep skirt block with aluminum cylinder head, 5-main bearing crankshaft, hydraulic valve lifters and electronic ignition reduce maintenance requirements. An automatic engine shut-down system protects the engine from high engine coolant temperature or low engine oil pressure. This engine is well known for low maintenance and long service life.

An optional Yanmar model 4TNV94, 2.8 liter (171 c.i.) 4 cylinder Diesel engine with direct injection is also available. Vertical exhaust is standard on Diesel. 2004 EPA compliant, not U.L. listed.

Engine Accessories/Capacities

Electrical systems are 12 volt, negative ground, and 50 amp alternator with integral regulator on LPG and 40 amp on diesel engines. Low maintenance battery is rated at 550 cold cranking amps at 0°F (-18 °C) on LPG and 800 CCA on diesel engines. The heavy-duty engine air cleaner is easily serviced. An external high-mounted air intake with rain cap is provided.

Cooling system capacity is 6.7 quarts (6.3 L); engine oil capacity with filter is 4.0 quarts (4.2 L). Fuel tanks on dual fuel or diesel models are 9.8 gals. (37 L).

Transaxle

Featuring a CLARK Model TA-18 single-speed, full reversing, powershift transaxle. This rugged and proven CLARK transaxle is an integral unit with high ratio, industrial torque converter, full-floating drive axles and drum/shoe brakes. Equipped with electrically controlled directional control, fully modulated clutch packs and precise inching control system. Test ports, fluid check and full-flow oil filter are easily accessible. An integral oil cooler is located in the open core radiator. Electric shift control provides consistent shift operation; linkage wear and adjustment are eliminated. Full-floating drive axle design adds durability as only torsional forces,

not truck loads, are transmitted through the axle shafts. Transaxle clutch packs incorporate hydraulic modulation and cushioning systems to provide smooth engagement and protect internal components under rapid direction reversals. Highly accessible transaxle control, gear drive for hydraulic pump and spin-on full-flow lubricant filter are easily serviced.

Brakes

Self-energizing, hydraulic-actuated drum and shoe type service brakes. Heavy cast iron brake shoes, backing plates and drums with openings for lining inspection and adjustment. All components are asbestos-free. The brakes are accessed by removing the wheel hub, axleshaft and brake drum. The left hand actuated parking brake pedal actuates service brakes at both drive wheels, with electric transmission interrupt and fingertip release. The transmission is disengaged when the parking brake is applied.

Steering

Steering is full hydrostatic with tilt wheel, utilizing a compact axle beam and integral double-acting steer cylinder. High strength spindle assemblies incorporate kingpins and double metal sealed bearings to provide rugged, easily serviced assemblies. The steering linkage uses spherical bearings, double shear link pins and grease fittings. Rubber isolation mounts support the axle, absorb shock and reduce noise.

Hydraulics

A single gear driven pump provides fluid for hydraulic functions and steering. The priority-demand steering system conserves energy by supplying hydraulic fluid on demand only basis. The hydraulic tank is integral with the truck frame with an in-tank screen, and the in-tank return line filter is easily serviced without spill. A quick-connect pressure port allows convenient pressure checks.

The main hydraulic valve is a modular design, allowing additional auxiliary sections and adjustable for pressure and auxiliary flow requirements. Hydraulic tank cover incorporates return line fittings, dipstick and breather filter. Sump tank capacity is 10.0 gal. (38 L).

Upright Assembly

High visibility CLARK designed uprights are available in two stage, HiLo and triple stage full free lift designs and are configured to provide maximum forward visibility. A wide range of lift heights is available. Interlocking rail/nested roller upright design utilizes specially rolled inner rail and channel section outer rails. This provides high strength under all upright load conditions and greater tolerance to unbalanced loads. Uprights feature negative rail drop enabling upright rollers to be easily accessed for adjustment.

Tilt cylinders incorporate spherical bushings at both ends to extend seal life by minimizing axial cylinder loads. Hydraulic counterbalance valve prevents improper tilt cylinder operation, flow limiting valves protect against rapid carriage descent in the event of a line failure and a lowering control valve regulates lowering speeds. ITA Class II and III hook type carriages incorporate six main rollers and two side thrust rollers to resist deflection due to off center loads. Forks are upset forged and have adjustable fork locks; forks are retained by the load backrest extension.

Additional Features

A single auxiliary valve, internal hosing, sideshifter, two headlights mounted on the overhead guard, tail lights, brake lights, turn signals and flashers are all standard equipment. Other standard features are open core radiator, high air intake, tow pin in the counterweight, rear tie-downs, low fuel warning indicator. The operator manual is permanently attached inside the rear pocket of the comfortable safety seat. Color is high visibility CLARK Green with matte black operator cell and upright. Wheels are bright white. CLARK’s Employer’s Guide to Material Handling Safety and operator safety video are provided with truck.



CLARK Europe GmbH

Neckarstraße 37
D - 45478 Mülheim an der Ruhr
Tel. +49 208 377336 0
Fax +49 208 377336 36
email: info-europe@clarkmheu.com
www.clarkmheu.com

Your authorized CLARK dealer is: