

CQ20/25/30

Diesel or LPG engine

Pneumatic or Superelastic Tires

2000 kg 2500 kg 3000 kg

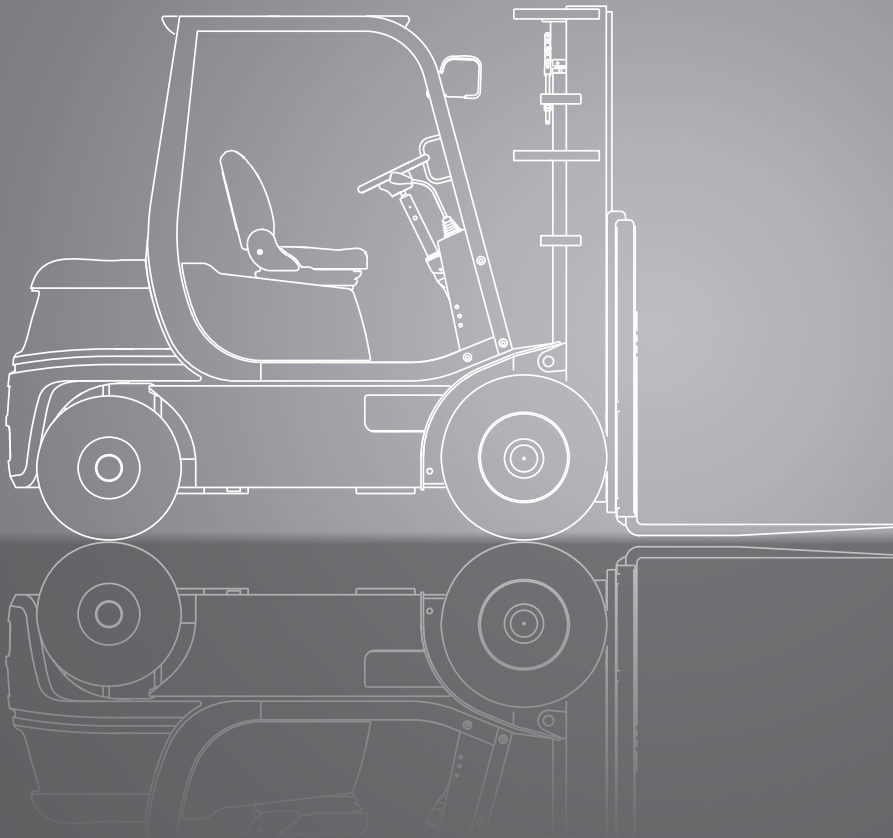

DIMENSIONS

CQ20/25/30

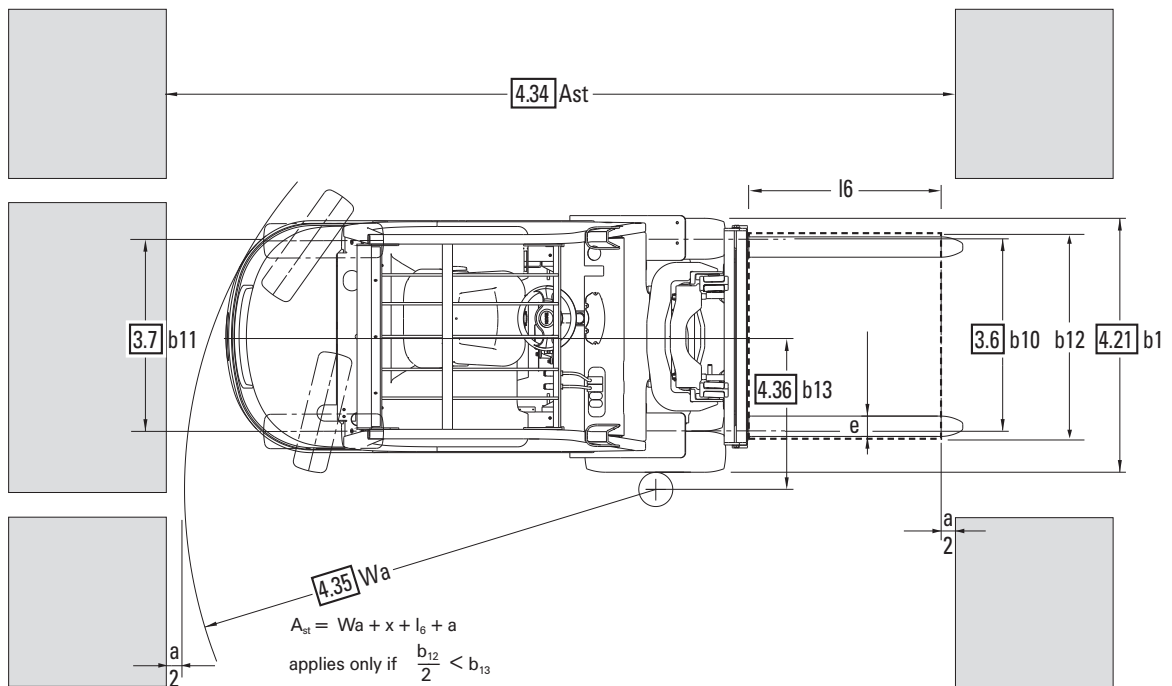
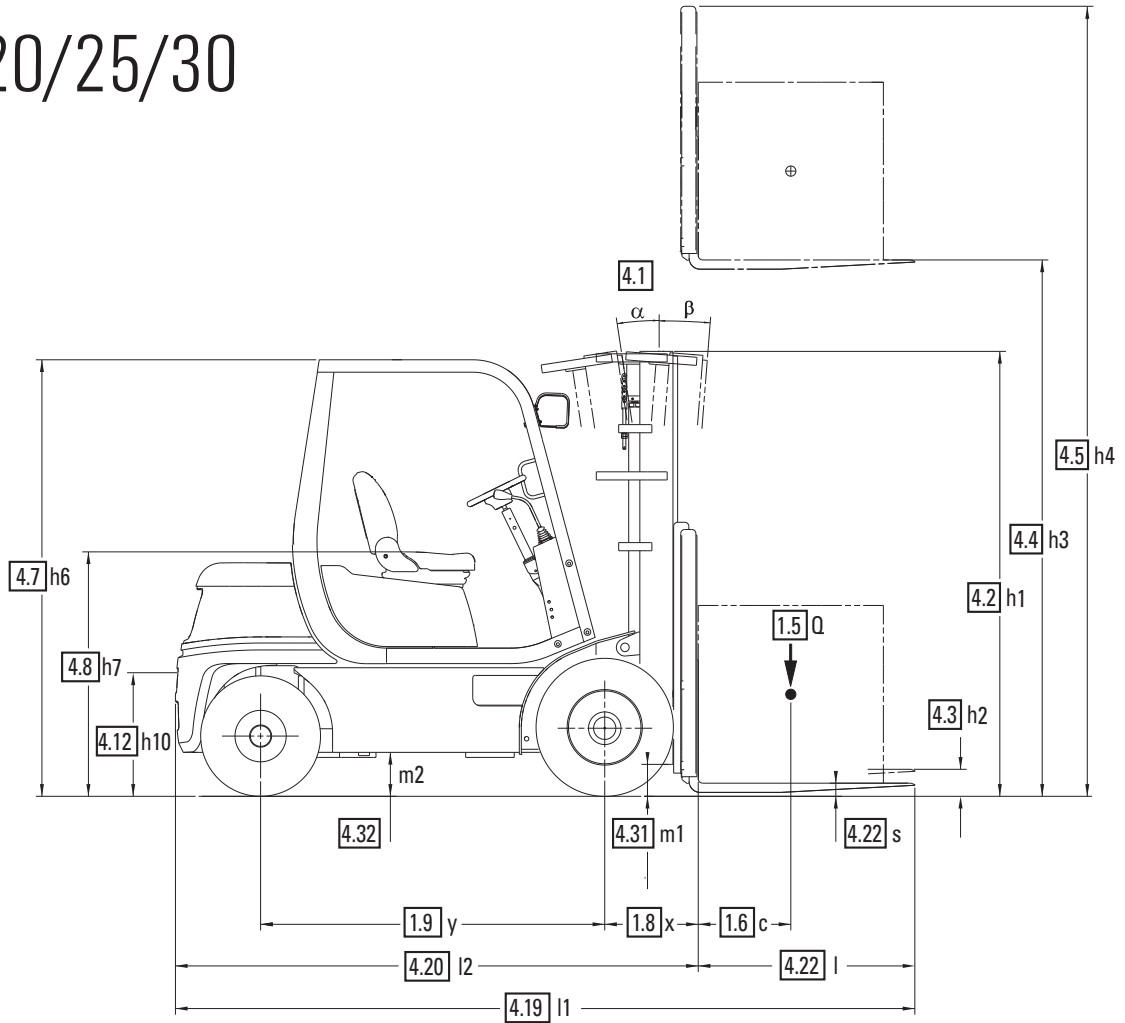

$$A_{st} = Wa + x + l_6 + a$$

applies only if $\frac{b_{12}}{2} < b_{13}$

$$A_{st} = Wa + \sqrt{(l_6 + x)^2 + \left(\frac{b_{12}}{2} - b_{13}\right)^2} + a$$

applies only if $\frac{b_{12}}{2} \geq b_{13}$

$$a = 200$$

GENERAL DATA

Truck Capacities Capacity at different load centres

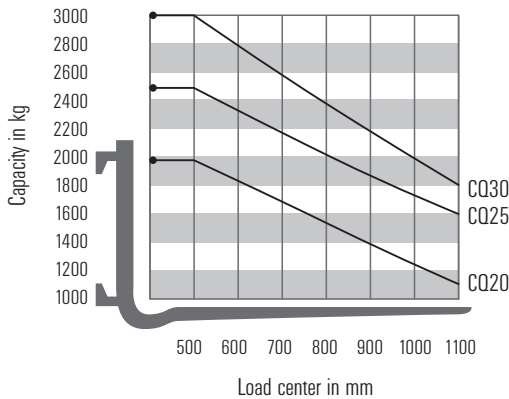

Note:

The listed capacities are valid only for the standard upright in vertical position with standard fork carriage and standard forks, up to max. lifting height of 3300 mm. The centre of gravity of the load may be displaced by max. 100 mm against the longitudinal centre plane of the truck. Load centre is determined from top and front face of the forks. The values are based on a 1000 mm cube load configuration with the centre of gravity at the true centre of the cube. With upright tilted forward lower capacity values are valid. Attachments, longer forks, exceptional load dimensions and higher lifting heights can reduce the capacity. Please talk to your CLARK dealer if you require further information.

Upright table CQ20/25

Mast type	Maximum Fork Height (h3)	Mast Lowered (h1)	Mast Extended (h4)		Free Lift (h2)	
			with load backrest	without load backrest	with load backrest	without load backrest
	mm	mm	mm	mm	mm	mm
Standard	2120	1575	3353	2716	110	110
	2680	1855	3913	3276		
	2980	2005	4213	3576		
	3300	2165	4533	3896		
	3725	2455	4958	4321		
	3860	2530	5093	4456		
	4165	2800	5398	4761		
	4380	3000	5613	4976		
	4620	3230	5853	5216		
5170	3495	6403	5766			
Triple	3860	1855	5093	4526	622	1189
	4320	2005	5553	4986	772	1339
	4800	2165	6033	5466	932	1499
	5210	2305	6443	5876	1072	1639
	5520	2455	6753	6186	1222	1789
	5740	2530	6973	6406	1297	1864
	6100	2690	7333	6766	1457	2024
	6370	2800	7603	7036	1567	2134
	6830	3000	8063	7496	1767	2334
7315	3230	8548	7981	1997	2564	
HI-LO	2935	2005	4168	3558	772	1382
	3255	2165	4488	3878	932	1542
	3530	2305	4763	4153	1072	1682
	3760	2455	4993	4383	1222	1832
	3910	2530	5143	4533	1297	1907

Upright table CQ30

Mast type	Maximum Fork Height (h3)	Mast Lowered (h1)	Mast Extended (h4)		Free Lift (h2)	
			with load backrest	without load backrest	with load backrest	without load backrest
	mm	mm	mm	mm	mm	mm
Standard	2120	1590	3356	2786	110	110
	2680	1870	3916	3346		
	2980	2020	4216	3646		
	3300	2180	4536	3966		
	3725	2470	4961	4391		
	3860	2545	5096	4526		
	4165	2815	5401	4831		
	4380	3015	5616	5046		
	4620	3245	5856	5286		
5170	3510	6406	5836			
Triple	3860	1870	5096	4548	634	1182
	4320	2020	5556	5008	784	1332
	4800	2180	6036	5488	944	1492
	5210	2320	6446	5898	1084	1632
	5520	2470	6756	6208	1234	1782
	5740	2545	6976	6428	1309	1857
	6100	2705	7336	6788	1469	2017
	6370	2815	7606	7058	1579	2127
	6830	3015	8066	7518	1779	2327
7315	3245	8551	8003	2009	2557	
HI-LO	2935	2020	4171	3623	784	1332
	3255	2180	4491	3943	944	1492
	3530	2320	4766	4218	1084	1632
	3760	2470	4996	4448	1234	1782
	3910	2545	5146	4598	1309	1857

SPECIFICATIONS

Product Specifications acc. to VDI 2198

	1.1 Manufacturer (Abbreviation)	CLARK	CLARK	CLARK	
Specifications	1.2 Manufacturer's designation	CQ20D	CQ25D	CQ30D	
	1.3 Drive unit Diesel, L.P. Gas	Diesel	Diesel	Diesel	
	1.4 Operator type stand on / driver seated	Driver seated	Driver seated	Driver seated	
	1.5 Load capacity / rated load	Q (Kg)	2000	2500	3000
	1.6 Load centre distance	c (mm)	500	500	500
	1.8 Load centre distance, centre of drive axle to fork face	x (mm)	452	452	462
	1.9 Wheelbase	y (mm)	1620	1620	1700
Weight	2.1 Service weight	kg	3511	3741	4110
	2.2 Axle loading, laden front / rear	kg	4800/711	5528/713	6337/773
	2.3 Axle loading, unladen front / rear	kg	1625/1886	1558/2183	1639/2471
Tires, Chassis	3.1 Tyre type, P = Pneumatic, SE = Superelastic Tires *1	P	P	P	
	3.2 Tyre size, front	7,00X12-14PR	7,00X12-14PR	8,15X15-14PR	
	3.3 Tyre size, rear	6,50X10-10PR	6,50X10-10PR	6,50X10-10PR	
	3.5 Wheels, number front/rear (x = drive wheels)	2X/2	2X/2	2X/2	
	3.6 Tread, front	b10 (mm)	1005	1005	1030
	3.7 Tread, rear	b11 (mm)	940	940	940
	Dimensions	4.1 Tilt of upright/fork carriage, α / β	Grad	10/8	10/8
4.2 Height, upright lowered		h1 (mm)	2165	2165	2180
4.3 Freelift		h2 (mm)	110	110	110
4.4 Lift height *2		h3 (mm)	3300	3300	3300
4.5 Height, upright extended (with LBR)		h4 (mm)	4533	4533	4536
4.7 Height overheadguard Std /cabin		h6 (mm)	2130(2140)	2130 (2140)	2130 (2140)
4.8 Seat height		h7 (mm)	1090	1090	1090
4.12 Coupling height		h10 (mm)	412	412	412
4.19 Overall length		l1 (mm)	3630	3630	3730
4.20 Length to face of forks		l2 (mm)	2560	2560	2660
4.21 Width		b1. b2 (mm)	1210	1210	1250
4.22 Fork dimensions		s • e • l (mm)	45X100X1070	45X100X1070	45X100X1070
4.23 Fork carriage DIN 15173, A, B			IIA	IIA	IIIA
4.24 Fork carriage width		b3 (mm)	1041	1041	1041
4.31 Ground clearance minimum		m1 (mm)	135	135	150
4.32 Ground clearance centre of wheelbase		m2 (mm)	175	175	175
4.33 Aisle width for pallets (I6-b12) 1000 x 1200 crossways		Ast (mm)	4027	4027	4145
4.34 Aisle width for pallets (I6-b12) 800 x 1200 lengthways	Ast (mm)	4227	4227	4345	
4.35 Outside turning radius	Wa (mm)	2375	2375	2485	
4.36 Smallest pivot point distance	b13 (mm)	822	822	822	
Performance	5.1 Travel speed laden/unladen	km/h	19,5/19,8	19,4/19,8	20,0/20,5
	5.2 Lift speed laden/unladen	m/s	0,55/0,58	0,54/0,58	0,53/0,58
	5.3 Lowering speed laden/unladen	m/s	0,46/0,43	0,46/0,43	0,46/0,43
	5.5 drawbar pull laden/unladen *3	N	17554	17652	16671
	5.6 Max. drawbar pull laden/unladen *3	N	18731/9718	18878/9640	17878/10081
	5.7 gradeability laden/unladen *3	%	34,3	29,8	24,4
	5.8 Max. gradeability laden/unladen *3	%	37,0/24,2	32,1/22,1	26,3/21,0
	5.9 Acceleration time laden/unladen (0 - 15 m)	s	4,5/4,1	4,8/4,3	5,0/4,3
	5.10 Service brake		Drum brake	Drum brake	Drum brake
	Drive line	7.1 Manufacturer / Type *4		Yanmar/4TNE98	Yanmar/4TNE98
7.2 Rated output acc. To ISO 1585		kW	43,6	43,6	43,6
7.3 Rated speed		min-1	2300	2300	2300
7.4 No. of cylinders / displacement		/cm ³	4/3319	4/3319	4/3319
7.5 Fuel consumption acc. VDI-Cyclus		Diesel = l/h. Treibgas = kg/h	-	-	-
Miscellaneous	8.1 Drive motor control		Torque converter	Torque converter	Torque converter
	8.2 Operating pressure for attachments	bar	140	140	140
	8.3 Oil volume for attachments	l/min	-	-	-
	8.4 Sound level, driver's ear *5	dB (A)	83	83	83
	8.5 Towing coupling, class/type DIN		-	-	-

1) Optional with super-elastic tyres *2Futher lift heights see upright table *3 with 1.6 km/h Without load at friction coefficient $\mu=0.8$ *4 Diesel = Tier3 / LPG = Tier *5 Equivalent permanent sound-pressure level L_{pAeq, T} in accordance with DIN EN 12053 (previously DIN 45635-36)

All values shown are for standard lift truck with standard equipment. If the truck is supplied with options, values may change. All values given may vary +5% and -10% due the motor and system tolerances and represent nominal values obtained under typical operating conditions. Specifications for Non-emission limited truck.

SPECIFICATIONS

Product Specifications acc. to VDI 2198

	1.1 Manufacturer (Abbreviation)	CLARK	CLARK	CLARK
Kennzeichen	1.2 Manufacturer's designation	CQ20L	CQ25L	CQ30L
	1.3 Drive unit Diesel, L.P. Gas	L.P. Gas	L.P. Gas	L.P. Gas
	1.4 Operator type stand on / driver seated	Driver seated	Driver seated	Driver seated
	1.5 Load capacity / rated load Q (Kg)	2000	2500	3000
	1.6 Load centre distance c (mm)	500	500	500
	1.8 Load centre distance, centre of drive axle to fork face x (mm)	452	452	462
	1.9 Wheelbase y (mm)	1620	1620	1700
Gewicht	2.1 Service weight kg	3446	3676	4070
	2.2 Axle loading, laden front / rear kg	4748/698	5493/683	6267/803
	2.3 Axle loading, unladen front / rear kg	1573/1873	1524/2152	1570/2500
Räder, Fahrwerk	3.1 Tyre type, P = Pneumatic, SE = Superelastic Tires *1	P	P	P
	3.2 Tyre size, front	7,00X12-14PR	7,00X12-14PR	8,15X15-14PR
	3.3 Tyre size, rear	6,50X10-10PR	6,50X10-10PR	6,50X10-10PR
	3.5 Wheels, number front/rear (x = drive wheels)	2X/2	2X/2	2X/2
	3.6 Tread, front b10 (mm)	1005	1005	1030
	3.7 Tread, rear b11 (mm)	940	940	940
	Grundabmessungen	4.1 Tilt of upright/fork carriage, α / β Grad	10/8	10/8
4.2 Height, upright lowered h1(mm)		2165	2165	2180
4.3 Freelift h2(mm)		110	110	110
4.4 Lift height *2 h3(mm)		3300	3300	3300
4.5 Height, upright extended (with LBR) h4(mm)		4533	4533	4536
4.7 Height overheadguard Std /cabin h6(mm)		2130 (2140)	2130 (2140)	2130 (2140)
4.8 Seat height h7(mm)		1090	1090	1090
4.12 Coupling height h10(mm)		412	412	412
4.19 Overall length l1(mm)		3630	3630	3730
4.20 Length to face of forks l2(mm)		2560	2560	2660
4.21 Width b1, b2 (mm)		1210	1210	1250
4.22 Fork dimensions s • e • l (mm)		45X100X1070	45X100X1070	45X100X1070
4.23 Fork carriage DIN 15173, A, B		IIA	IIA	IIIA
4.24 Fork carriage width b3 (mm)		1041	1041	1041
4.31 Ground clearance minimum m1 (mm)		135	135	150
4.32 Ground clearance centre of wheelbase m2 (mm)		175	175	175
4.33 Aisle width for pallets (I6-b12) 1000 x 1200 crossways Ast(mm)	4027	4027	4145	
4.34 Aisle width for pallets (I6-b12) 800 x 1200 lengthways Ast(mm)	4227	4227	4345	
4.35 Outside turning radius Wa(mm)	2375	2375	2485	
4.36 Smallest pivot point distance b13 (mm)	822	822	822	
Leistungsdaten	5.1 Travel speed laden/unladen km/h	20,4/20,6	20,6/20,1	19,5/20,6
	5.2 Lift speed laden/unladen m/s	0,50/0,54	0,48/0,54	0,46/0,54
	5.3 Lowering speed laden/unladen m/s	0,46/0,43	0,46/0,43	0,46/0,43
	5.5 drawbar pull laden/unladen *3 N	13543	13563	12347
	5.6 Max. drawbar pull laden/unladen *3 N	14828/9718	14877/9434	13416/9669
	5.7 gradeability laden/unladen *3 %	25,9	22,7	17,9
	5.8 Max. gradeability laden/unladen *3 %	28,5/25,9	25,1/22,0	19,5/20,5
	5.9 Acceleration time laden/unladen (0 - 15 m) s	5,3/4,5	5,5/4,6	6,0/4,8
	5.10 Service brake	Drum brake	Drum brake	Drum brake
	Antrieb	7.1 Manufacturer / Type *4	Mitsubishi 4G64	Mitsubishi 4G64
7.2 Rated output acc. To ISO 1585 kW		32,8	32,8	32,8
7.3 Rated speed min-1		2200	2200	2200
7.4 No. of cylinders / displacement /cm ³		4/2350	4/2350	4/2350
7.5 Fuel consumption acc. VDI-Cyclus Diesel = l/h. Treibgas = kg/h		-	-	-
Sonstige	8.1 Drive motor control	Torque converter	Torque converter	Torque converter
	8.2 Operating pressure for attachments bar	140	140	140
	8.3 Oil volume for attachments l/min	-	-	-
	8.4 Sound level, driver's ear *5 dB (A)	83	83	83
	8.5 Towing coupling, class/type DIN	-	-	-

1) Optional with super-elastic tyres *2Furter lift heights see upright table *3 with 1.6 km/h Without load at friction coefficient $\mu=0.8$ *4 Diesel = Tier3 / LPG = Tier *5 Equivalent permanent sound-pressure level L_{pAeq, T} in accordance with DIN EN 12053 (previously DIN 45635-36)

All values shown are for standard lift truck with standard equipment. If the truck is supplied with options, values may change. All values given may vary +5% and -10% due the motor and system tolerances and represent nominal values obtained under typical operating conditions. Specifications for Non-emission limited truck.

The CQ20-30 series from CLARK has been developed with the aim of offering you reliable trucks with simple yet durable components. This means low operating and maintenance costs combined with an extremely good price-performance ratio. The sturdy "built to last" upright, as used in the premium models of Clark's GEN2 series, as well as the robust design typical of CLARK, make these forklifts an ideal solution for diverse applications.

Driver's cab

A handle on the front column of the entry side makes it easier to climb up and down. The rubber floor covering in the footwell absorbs vibrations and ensures a firm foot grip. A tilting steering column and easy-to-adjust comfort seat allow adaptation to suit any driver.

To avoid confusion the pedal system is arranged in the same way as an automobile. The control levers are mounted on the front, in a position that enables perfect grip.

The important operating data is shown on a clear display directly in front of the operator.

An ingenious arrangement of chains and hoses on the upright means the driver has a wide field of vision.

A storage compartment in the ergonomic CLARK driver's seat is another plus point to the successful driver's cab.

Engine, Transmission

CLARK's CQ forklifts with LPG and diesel power come with world-acclaimed engines that have continually been proven in service. These sturdy engines have low noise and exhaust emissions. The 4 cylinder Mitsubishi 4G64 LPG engine producing 32.8 kW (44.6 HP) ensures smooth starting performance and quiet operation.

The Yanmar engine (4TNE98) with 43.6 kW at 2200 revolutions per minute in the diesel forklifts is just as impressive. Direct injection means this engine operates with especially low noise and emission levels.

An integrated unit with power-shift transmission and drive axle ensures that the transmission (TA18) and axle are protected against dirt ingress.

All engines comply with EU directives ensuring low exhaust emissions.

Brake system

Heavy duty self adjusting drum type service brakes and an easy-grip parking brake lever mounted on the front cowl ensure a high level of safety. Applying the parking brake automatically decouples the transmission and prevents driving against the brake.

Steering system

The Clark designed steer axle with dual acting steering cylinder enables a uniform steering ratio. The hydrostatic power steering makes steering easy with just a few turns of the steering wheel. Impacts on the steering wheel from road bumps are absorbed. The steer axle has pivotal bearings mounted in rubber steel elements. This increases driving comfort as impacts are absorbed – in addition, the rubber steel elements are completely maintenance free.

Hydraulic system

A full-flow reverse filtration filters the oil to the tank at each reverse flow. Rough particles are filtered directly via a suction line filter, thereby preventing contamination from entering the oil circuit ensuring a long service life for all hydraulic components. A large protected hydraulic tank ensures enough hydraulic oil is always available for all lift heights and attachments. The main hydraulic valve can be adjusted to suit attachment requirements.

A high-capacity pump provides adequate oil supply for the upright functions and hydrostatic steering, with a priority distributor ensuring steering priority in all conditions. Load handling is controlled via a load-sensitive response and precise control valve. A safety valve provides extra safety and prevents an uncontrolled lowering of the load.

Upright

The clear-view uprights are available in Standard, Hilo and Triplex versions. The heavy duty interlocked narrow profiles provide high strength, even under the heaviest load. Adjustable canted (Angled) upright rollers minimise deflection particularly when handling off-set or uneven loads.

The tilt cylinders are mounted in spherical bearings, preventing seal strain and premature leaks due to off –set loads. This consequently extends the service life of the complete cylinder. A tilt-lock valve integrated in the main control valve prevents too rapid or unintentional tilting of the upright.

The forks are forged and are maintained in the required position by adjustable locking pins.

A hydraulic cylinder damping system reduces impacts and vibrations during the transition between the individual upright levels, eliminating shocks and load damage. The strong fork carriage with sturdy thick for bars and adjustable side thrust rollers enhances the durability of this design, even during tough applications.

Additional standard equipment

Front headlights, pneumatic tyres, combination rear lights with brake light and white reversing light, paintwork in the bright safety colour "CLARK Green", driver's compartment and upright in black, rims in white.

Additional equipment

SE tyres, non-marking tyres, dual tyres, add-on units, cabs, acoustic reversing alarm, integrated or hook mounted side-shifts, high mounted quick release hydraulic connections, fork positioners, various seats and much more.

Safety

The CQ20-30 series is CE certified and corresponds to all European safety standards for forklifts.

Talk to your CLARK dealer to find the optimum equipment for you.

CLARK Europe GmbH

Neckarstraße 37
D - 45478 Mülheim an der Ruhr
Tel.+49 208 377336 0
Fax+49 208 377336 36

email: info-europe@clarkmheu.com
www.clarkmheu.com